

J-41425-NIS ALUMINUM TUBE REPAIR KIT

This kit features new style compression fittings for fast, easy and leak free line repairs.



WARNING Connectors in this kit are intended for Aluminum Tubing repairs only. Their use on any other type of vehicle tubing could cause failures resulting in bodily injury or death.

TUBE LENGTH REQUIREMENT

Check chart for minimum amount of straight tubing required for proper connector installation.

TUBE SIZE	MIN. TUBE LENGTH REQUIRED	
	DIM "A" STANDARD INSTALLATION	DIM "A" JAW REVERSED INSTALLATION
8mm	29mm	19mm - 29mm
3/8"	1 1/8" MIN.	3/4" - 1 1/8"
1/2"	1 1/8" MIN.	3/4" - 1 1/8"
12mm	29mm	19mm - 29mm
16mm	29mm	22mm - 32mm
19mm	34mm	22mm - 34mm

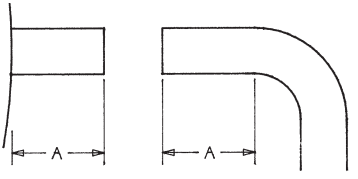

TOOL ASSEMBLY

Assemble tool by sliding the appropriate size jaws into the tool body.

- A.) For standard installation (see chart above), install the jaws with the rubber gripping pads facing outward.
- B.) For reversed jaw installation (see chart above), remove rubber gripping pad and install jaw with gripping pad area facing inward.

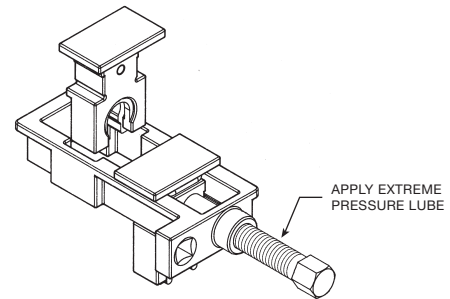
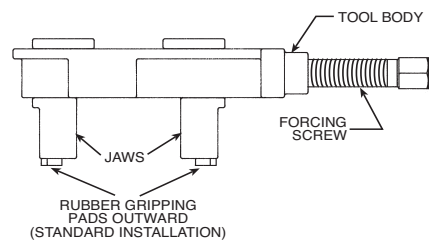

TUBE PREPARATION

- A tube cutter (like the one supplied in the kit) must be used to cut the tubes. This is to reduce burrs and to prevent foreign material from entering the open tube. Do not use a hack saw or other cutting tools.
- Clean 20mm minimum of tube ends with cleaning pad provided. To avoid longitudinal scratches in the tube, work with a rotational motion around the tube. (See Fig. A)
- Apply 1-3 drops of sealing compound (J-41425-3) to the outside of each tube end.
- Insert the tube ends into the connector and rotate the connector a complete turn to evenly distribute the sealing compound. (See Fig. B)

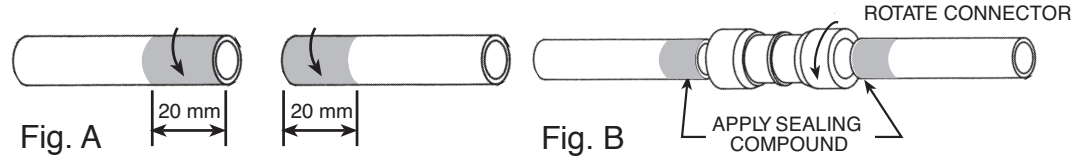

TOOL OPERATION

- Install tool over connector and tubes. Connector ends must be positioned in counter bores of the jaws. (See Fig. C)
- Turn the forcing screw with the appropriate hand tool only. Do not use power tools on the forcing screw or tool body. While holding the tool body with a 3/8" breaker bar, (see above) turn the forcing screw until both of the connector collars have bottomed on the center shoulder of the connector. (See Fig. D)
- Use hand tools only.

IMPORTANT!
TUBES MUST BE KEPT FULLY INSERTED INTO THE CONNECTOR TO OBTAIN A LEAK FREE JOINT.

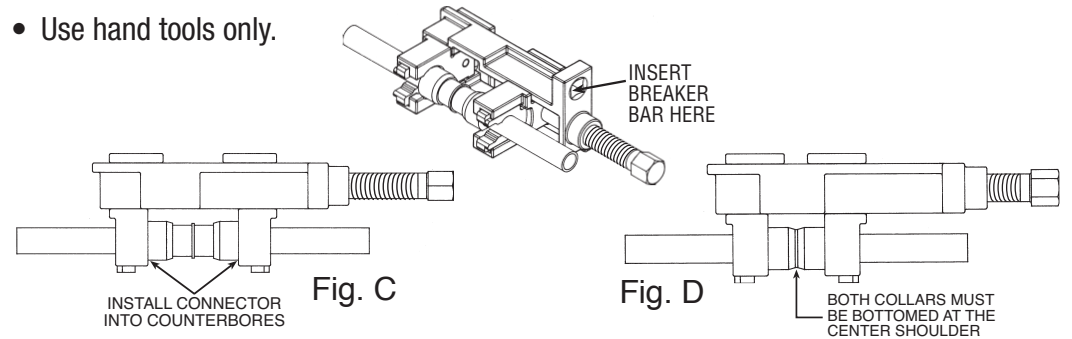

REORDERING INFORMATION	TUBE SIZE	A/C CONNECTOR REORDER NO. PACKAGE QTY. (5)	JAW ORDER NO.
	8mm	J-41425-NIS-8	J-41425-NIS-2
	12mm	J-41425-NIS-12	J-41425-NIS-3
	16mm	J-41425-NIS-16	J-41425-NIS-4
	19mm	J-41425-NIS-19	J-41425-NIS-5
	3/8"	J-41425-375*	J-41425-6*
	1/2"	J-41425-500*	J-41425-8*
		SEALING COMPOUND	J-41425-3
	CLEANING PADS	J-41425-23	
	MAIN BODY	J-41425-NIS-1	
	EXTREME PRESSURE LUBE	280934	
	TUBING CUTTER	551415	

*Available, not included in essential shipment

CALL 1-800-662-2001 FOR TECHNICAL ASSISTANCE OR REORDERING

